

Take on trail or field  
with the new

# grand prix<sup>®</sup>

MINI-BIKE



Here's a safe, rugged mini-bike in easy-to-assemble kit form. It's easily transported in car trunk or station wagon; then just raise the chrome-plated handle bars, lower foot pegs and scoot out over trail or field for fishing, hunting, commercial purposes, or just plain relaxing. Enjoy speeds up to 25 MPH. Get up to 100 miles per gallon — 3 miles for a single penny!

## SPECIFICATIONS

**ENGINE** — 3.5 HP Tecumseh, 4 cycle, recoil start

**CLUTCH** — Centrifugal

**DRIVE** — No. 35 roller chain

**TIRES** — Nylon, 2 ply, 12"

**BEARINGS** — Self-lubricating ball

**BRAKE** — Automotive-type expanding double shoe, hand-operated

**FRAME** — Rugged tubular steel

**WEIGHT** — Approx. 83 lbs.

Exclusive on Deluxe model: Spring-loaded telescoping front suspension, seat-mounted rear shock absorbers. Standard model offers all exciting features found on the Deluxe machine except for the suspension system. The Standard Mini-Bike gives you a top quality machine at minimum cost.

**NOTE:** Neither the Deluxe nor the Standard Grand Prix Mini-Bikes are intended for highway, street or sidewalk use and cannot be licensed.

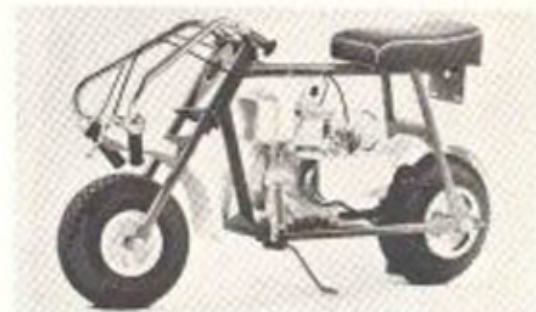
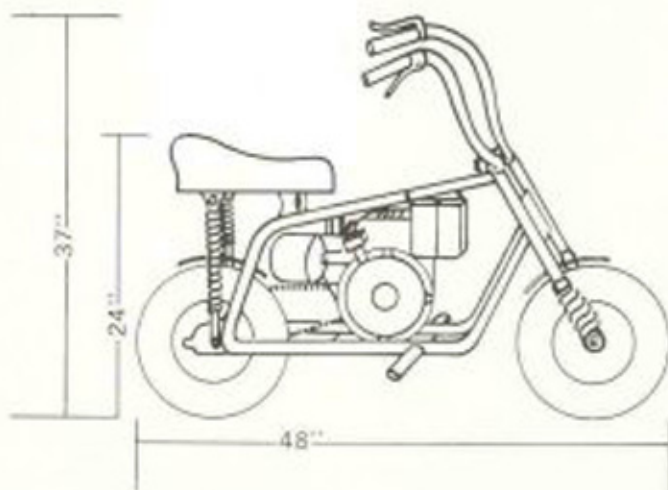

Standard model folds to 48" x 14" x 24"



Deluxe model folds to a compact 50" x 14" x 24"



# TRAIL



The rugged, high-performance, all-terrain

# BIKE TS-5

## A Two-Wheel Power House

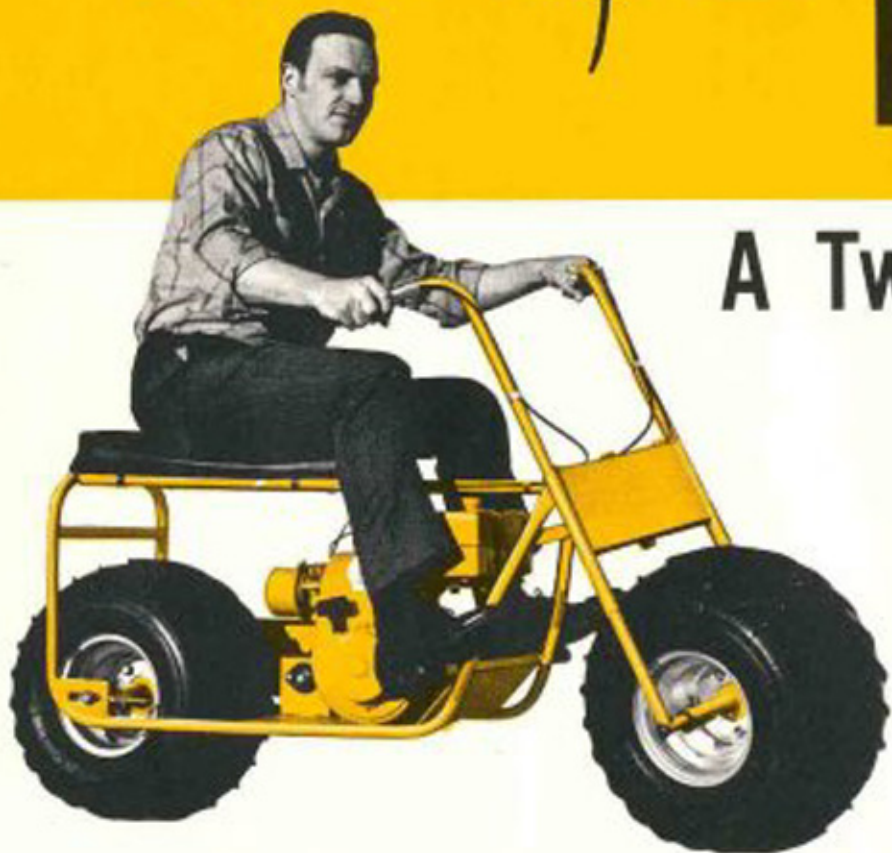

### go anywhere . . . in any weather

Built for the backwoods, where rugged power and dependable, sure-footed traction are necessary. Now you can enjoy the TS-5 Bike, an all-terrain vehicle engineered for year-round use. Its fishing, hunting and camping applications are unlimited, and the low-pressure 21" diameter tires give it stability and mobility over the snow. Whether you want the TS-5 Bike for personal enjoyment or as a piece of business equipment, this full sized machine is built to "take it".

Features include complete safety engineering throughout, a full length chain guard, a steel skid plate forward and beneath the engine, 7 H.P. engine, and an optional Forest Service-approved spark-arresting muffler.

### SPECIFICATIONS

**ENGINE** — 7 H.P. 4 cycle Tecumseh

**FRAME** — All steel, jig-welded heavy-duty tubular steel.

**CLUTCH** — "Cam-action" sintered iron shoe centrifugal.

**DRIVE** — #40 chain (2000 lbs. tensile strength) in both primary and secondary drives.

**SEAT** — Full 3"-thick foam with Naugahyde cover.

**BRAKE** — Band brake operates at over 10 to 1 ratio to wheel to give swift, positive stops. (Controlled with hand lever).

**THROTTLE** — Mounted on handle. "Deadman"-type linkage shuts down engine if operator releases control lever.

**CARRYING CAPACITY** — 300 lbs.

**TIRES** — High-flotation, 12" wide x 21" diameter, low pressure (1½-3 lbs.). (Same as those used on rear of our 4-wheel drive Mini-Beeep).

**CLIMB** — Approximately 40%.

**DIMENSIONS** — Length 66", width 25½", height at seat 28" height at handlebars 38½", wheelbase 46"

**GROUND CLEARANCE** — 7½".

**WEIGHT** — Approximately 135 lbs.





Shows the complete kit of TS-5 Bike parts as provided.



Shows the assembly of the front fork and wheels.



The engine, clutch and drive chains in position.



Band brake and handlebar controls for brake and throttle — installed.



Finished machine — right side.

This easy-to-assemble kit may be put together, using the complete, clearly-written instructions, in 3 hours or less. As with other Struck kits, the TS-5 Bike requires only minimum mechanical knowledge and tools.

#### TS-5 PLANS

A complete set of plans for building your own TS-5 Trail Bike from locally-sourced materials. Complete set of drawings (identical to those we use in our own production) plus detailed assembly instructions. You also get a complete parts list with low "factory direct" prices on all parts you don't wish to fabricate yourself.

TS-5 PLANS . . . . . \$2.00



Complete machine, showing chain guard in place.

