

1978

# ENGINE SPECIFICATIONS

# TECUMSEH

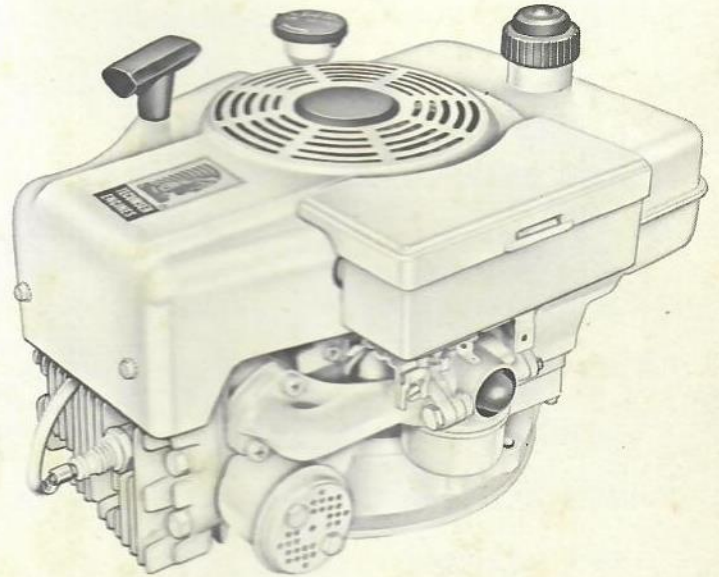
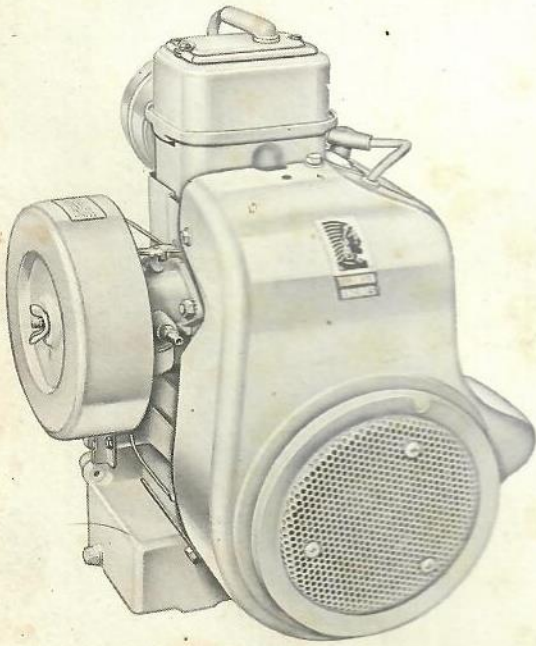

**TECUMSEH PRODUCTS COMPANY**

PARTS DEPOT

900 NORTH STREET

GRAFTON, WISCONSIN U.S.A. 53024

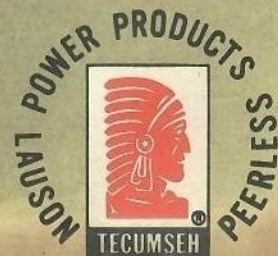

## TABLE OF CONTENTS

	<u>PAGES</u>
TABLE OF CONTENTS.....	2
SELECTING A REPLACEMENT ENGINE BY COMPARING SPECIFICATIONS.....	3
TECUMSEH NUMERICAL SERVICE NUMBER SYSTEM.....	3
<b>VERTICAL ENGINE SPECIFICATIONS (4 CYCLE)</b>	
TVS90 - 9.05 C.I. DISPLACEMENT .....	4
TVS105 - 10.49 C.I. DISPLACEMENT .....	5
TNT100 - 10.00 C.I. DISPLACEMENT .....	6
TNT120 - 12.00 C.I. DISPLACEMENT .....	7
3.5 HORSEPOWER .....	8 - 10
4.0 HORSEPOWER .....	11
5.0 HORSEPOWER .....	12 - 14
6.0 HORSEPOWER .....	15 - 17
7.0 HORSEPOWER .....	18 & 19
8.0 HORSEPOWER .....	20
10.0 HORSEPOWER .....	21
<b>HORIZONTAL ENGINE SPECIFICATIONS (4 CYCLE)</b>	
3.0 HORSEPOWER .....	22
3.5 HORSEPOWER .....	23 - 26
4.0 HORSEPOWER .....	27 - 29
5.0 HORSEPOWER .....	30 - 35
6.0 HORSEPOWER .....	36 & 37
7.0 HORSEPOWER .....	38 - 41
8.0 HORSEPOWER .....	42 - 44
10.0 HORSEPOWER .....	45 & 46
12.0 HORSEPOWER .....	47
14.0 HORSEPOWER .....	48
16.0 HORSEPOWER .....	49 & 50
<b>VERTICAL ENGINE SPECIFICATIONS (2 CYCLE)</b>	
3.0 HORSEPOWER .....	51 & 52
<b>HORIZONTAL ENGINE SPECIFICATIONS (2 CYCLE)</b>	
2.0 HORSEPOWER .....	53
5.0 HORSEPOWER .....	54
ACCESSORIES .....	55 & 56
CROSS REFERENCE LIST.....	57

## SELECTING A REPLACEMENT ENGINE BY COMPARING SPECIFICATIONS

If the model or type number of the old engine is not shown in the Engine Replacement List, or if the model or type number is unknown, proceed as follows:

1. First, list the number which represents the **CRANKSHAFT POSITION**.
2. Now, determine the **HORSEPOWER** required. (Two cycle is designated by 00 in the second and third digit position.)
3. Determine **PRIMARY FEATURES** required.
4. Refer to **VERTICAL ENGINE SPECIFICATIONS** or **HORIZONTAL ENGINE SPECIFICATIONS** for specific variations.

Engines not in shaded areas are of a standard design and are usually painted standard Tecumseh replacement engine white.

Engines in the shaded areas are specially built for specific OEMs and therefore, because of color, etc., are not suitable to be sold to an Assigned OEM.

### TECUMSEH NUMERICAL SERVICE NUMBER SYSTEM

(EXAMPLE) 8 0 4 1 0 1 A

1st DIGIT	2nd & 3rd DIGIT	4th DIGIT	5th & 6th DIGIT	7th DIGIT
CRANKSHAFT POSITION	HORSEPOWER OR 2 CYCLE	PRIMARY FEATURES	ENGINE VARIATION NUMBER	REVISION LETTER
8 - Vertical 9 - Horizontal	00 = 2 Cycle 02 = 3 H.P. 03 = 3.5 H.P. 04 = 4 H.P. 05 = 5 H.P. 06 = 6 H.P. 07 = 7 H.P. 08 = 8 H.P. 10 = 10 H.P. 12 = 12 H.P. 14 = 14 H.P. 16 = 16 H.P.	1 = Rotary Mower 2 = Industrial 3 = Snow King 4 = Mini Bike 5 = Tractor 6 = Tiller 7 = Rider	00 thru 99 00 thru 99 00 thru 99 00 thru 99 00 thru 99 00 thru 99 00 thru 99	

# 3 HORSEPOWER (SMALL FRAME) TILLER APPLICATION

## STANDARD EQUIPMENT & DIMENSIONS

<b>MODEL</b>	<b>H30</b>	
<b>HORSEPOWER @ 3600 RPM</b>	<b>3.0</b>	
<b>BORE &amp; STROKE</b>	<b>INCHES</b>	<b>2-5/16 x 1-27/32</b>
	<b>MILLIMETERS</b>	<b>58.74 x 46.84</b>
<b>DISPLACEMENT</b>	<b>CUBIC INCHES</b>	<b>7.75</b>
	<b>CUBIC CENTIMETERS</b>	<b>126.93</b>
<b>LUBRICATION</b>	<b>Splash</b>	
<b>GOVERNOR</b>	<b>Mechanical</b>	
<b>OIL CAPACITY</b>	<b>OUNCES</b>	<b>21</b>
	<b>MILLILITERS</b>	<b>620</b>
<b>NET WEIGHT (APPROX.)</b>	<b>POUNDS</b>	<b>25</b>
	<b>KILOGRAMS</b>	<b>11.3</b>
<b>LENGTH "A" (IN INCHES)</b>	<b>17-1/8</b>	
<b>HEIGHT "B" (IN INCHES)</b>	<b>13-43/64</b>	
<b>WIDTH "C" (IN INCHES)</b>	<b>10-39/64</b>	
<b>BOLT MTG. CIRCLE (IN INCHES)</b>	<b>3-5/8</b>	

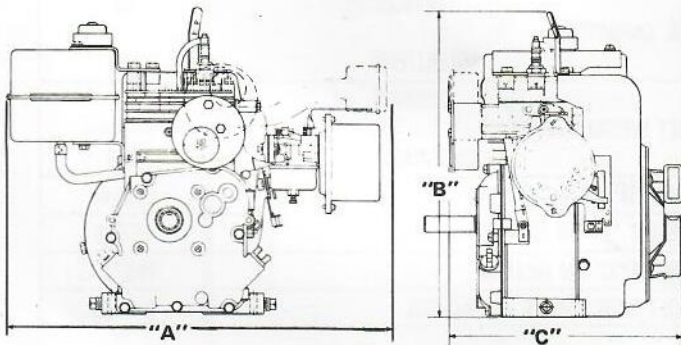
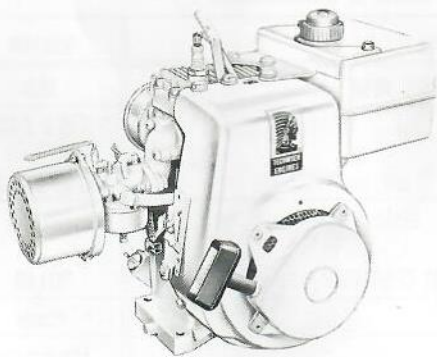

## ENGINE VARIATIONS

CRANKSHAFT Length of crankshaft is measured from drilled and tapped face on the cover plate to end of shaft.				OTHER CRANKSHAFT SPECIFICATIONS	FUEL TANK CAPACITY IN QUARTS	PULSE TYPE FUEL PUMP	EXHAUST DIRECTION	AUXILIARY P.T.O. SHAFT	CARBURETOR	BALL BEARING CONTROLS	MAGNETO FEATURE	STARTER	REGULATOR	AIR CLEANER	OIL FILLER TUBE	OIL DRAIN	BOLT MTG. CIRCLE - SEE NOTES	CAST IRON	FAST MOVING ENGINES
SERVICE NUMBER	PART NUMBER	DIAMETER	LENGTH																
SERIES 902000 (HORIZONTAL 3.0 H.P.)																			
902600	30878A	3/4"	2-29/64"	5/16-24 Tap, 3/16x1-7/8Kw	PS	2	FI	M	X	Re			P	DS					STD ■

## NOTES

DS Dual sides oil drain  
FI Float carburetor  
Kw Keyway

M Manual control  
P Paper air cleaner  
PS P.T.O. side

Re Rewind starter  
STD Standard Engine  
■ This engine is not eligible for return.

# 3.5 HORSEPOWER (SMALL FRAME) INDUSTRIAL APPLICATION

## STANDARD EQUIPMENT & DIMENSIONS

<b>MODEL</b>	<b>H35</b>	
<b>HORSEPOWER @ 3600 RPM</b>	3.5	
<b>BORE &amp; STROKE</b>	<b>INCHES</b>	2-1/2 x 1-27/32
	<b>MILLIMETERS</b>	63.50 x 46.84
<b>DISPLACEMENT</b>	<b>CUBIC INCHES</b>	9.05
	<b>CUBIC CENTIMETERS</b>	148.34
<b>LUBRICATION</b>	Splash	
<b>GOVERNOR</b>	Mechanical	
<b>OIL CAPACITY</b>	<b>OUNCES</b>	21
	<b>MILLILITERS</b>	620
<b>NET WEIGHT (APPROX.)</b>	<b>POUNDS</b>	25
	<b>KILOGRAMS</b>	11.3
<b>LENGTH "A" (IN INCHES)</b>	17-1/8	
<b>HEIGHT "B" (IN INCHES)</b>	13-43/64	
<b>WIDTH "C" (IN INCHES)</b>	10-39/64	
<b>BOLT MTG. CIRCLE (IN INCHES)</b>	3-5/8	

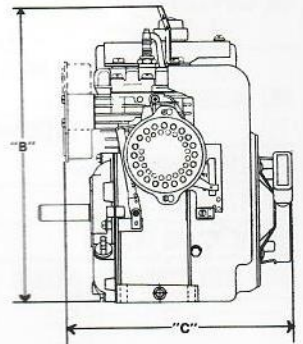
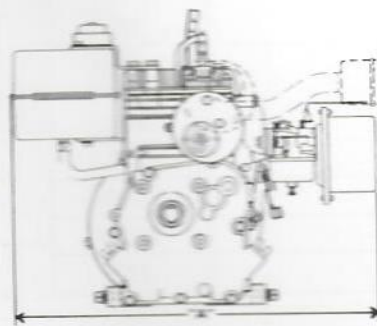
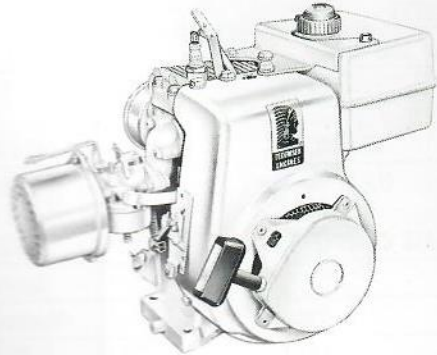

## ENGINE VARIATIONS

CRANKSHAFT				OTHER CRANKSHAFT SPECIFICATIONS	FUEL TANK CAPACITY IN QUARTS	PULSE TYPE FUEL PUMP	CARBURETOR	BALL BEARING CONTROLS	MAGNETO FEATURE STARTER	OIL FILLER TUBE AIR CLEANER REGULATOR	OIL DRAIN	BOLT MTG. CIRCLE - SEE NOTES	CAST IRON	FAST MOVING ENGINES SEE NOTES
SERVICE NUMBER	PART NUMBER	DIAMETER	LENGTH											
Length of crankshaft is measured from drilled and tapped face on the cover plate to end of shaft.														
SERIES 903000 (HORIZONTAL 3.5 H.P.)														
903210	30860	3/4"	2-21/64"	3/4-16 Thread	CS	2	FI	M	X	Re	P	DS		STD ■
903220	32105A	3/4"	2-27/64"	3/8-24 Tap, 3/16x1-7/8Kw	CS	2	FI	M	X	Re	P	DS		STD ■

## NOTES

CS Carburetor side  
DS Dual sides oil drain  
FI Float carburetor

Kw Keyway  
M Manual control  
P Paper air cleaner

Re Rewind starter  
STD Standard Engine  
■ This engine is not eligible for return.

# 3.5 HORSEPOWER (SMALL FRAME) SNOW KING APPLICATION

## STANDARD EQUIPMENT & DIMENSIONS

MODEL		H35
HORSEPOWER @ 3600 RPM		3.5
BORE & STROKE	INCHES	2-1/2 x 1-27/32
	MILLIMETERS	63.50 x 46.84
DISPLACEMENT	CUBIC INCHES	9.05
	CUBIC CENTIMETERS	148.34
LUBRICATION		Splash
GOVERNOR		Mechanical
OIL CAPACITY	OUNCES	21
	MILLILITERS	620
NET WEIGHT (APPROX.)	POUNDS	26
	KILOGRAMS	11.8
LENGTH "A" (IN INCHES)		14-7/8
HEIGHT "B" (IN INCHES)		13-21/64
WIDTH "C" (IN INCHES)		10-39/64
BOLT MTG. CIRCLE (IN INCHES)		3-5/8

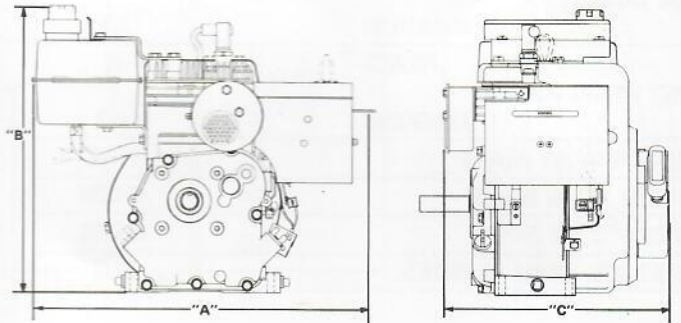
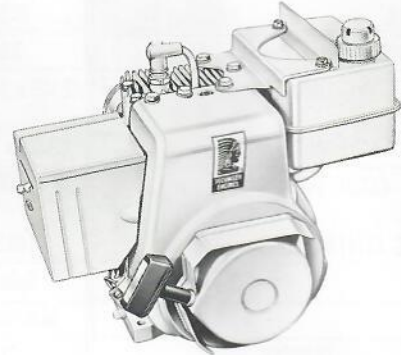

## ENGINE VARIATIONS

CRANKSHAFT				OTHER CRANKSHAFT SPECIFICATIONS	AUXILIARY P.T.O. SHAFT	FUEL TANK CAPACITY IN QUARTS	EXHAUST DIRECTION	PULSE TYPE FUEL PUMP	CARBURETOR	BALL BEARING CONTROLS	MAGNETO STARTER	MAGNETO FEATURE	REGULATOR	AIR CLEANER	OIL FILLER TUBE	OIL DRAIN	BOLT MTG. CIRCLE - SEE NOTES	CAST IRON	FAST MOWING ENGINES SEE NOTES
SERVICE NUMBER	PART NUMBER	DIAMETER	LENGTH																
Length of crankshaft is measured from drilled and tapped face on the cover plate to end of shaft.																			
SERIES 903000 (HORIZONTAL 3.5 H.P.)																			
903361	31737	3/4"	2-27/64"	3/16 x 1-7/8Kw		2:1	PS	1		D	M		Re	RG			DS		A± 9

## NOTES

A Ariens  
D Diaphragm carburetor  
DS Dual sides oil drain  
Kw Keyway

M Manual control  
PS P.T.O. side  
Re Rewind starter  
RG Ring gear on flywheel

± This engine is not eligible for after-market O.E.M. Discount.  
9 No.-33290A - 120 Volt Electric Starter can be installed.

# 3.5 HORSEPOWER (SMALL FRAME) MINI BIKE APPLICATION

## STANDARD EQUIPMENT & DIMENSIONS

MODEL	H35	
HORSEPOWER @ 3600 RPM	3.5	
BORE & STROKE	INCHES	2-1/2 x 1-27/32
	MILLIMETERS	63.50 x 46.84
DISPLACEMENT	CUBIC INCHES	9.05
	CUBIC CENTIMETERS	148.34
LUBRICATION	Splash	
GOVERNOR	Mechanical	
OIL CAPACITY	OUNCES	21
	MILLILITERS	620
NET WEIGHT (APPROX.)	POUNDS	26
	KILOGRAMS	11.8
LENGTH "A" (IN INCHES)	17-1/8	
HEIGHT "B" (IN INCHES)	13-43/64	
WIDTH "C" (IN INCHES)	9-9/32	
BOLT MTG. CIRCLE (IN INCHES)	3-5/8	

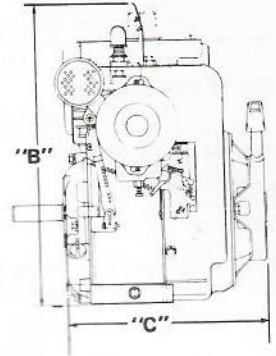
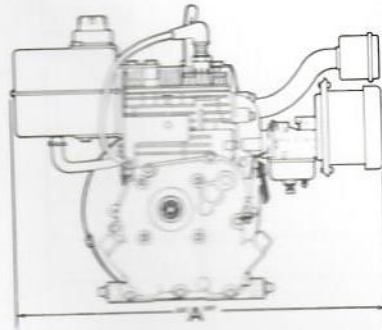
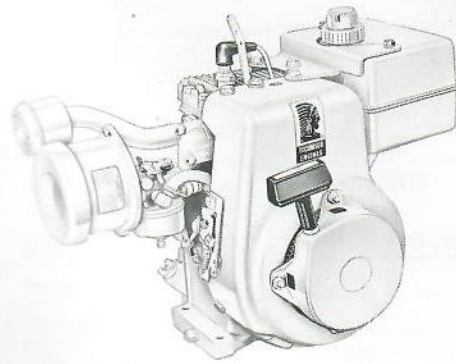

## ENGINE VARIATIONS

CRANKSHAFT Length of crankshaft is measured from drilled and tapped face on the cover plate to end of shaft.				OTHER CRANKSHAFT SPECIFICATIONS														FAST MOVING ENGINES			
SERVICE NUMBER	PART NUMBER	DIAMETER	LENGTH	FUEL TANK CAPACITY IN QUARTS	PULSE TYPE FUEL PUMP	AUXILIARY P.T.D. SHAFT	EXHAUST DIRECTION	CARBURETOR	CONTROLS	BALL BEARING	MAGNETO FEATURE	STARTER	REGULATOR	AIR CLEANER	OIL FILLER TUBE	OIL CLEANER	OIL DRAIN	BOLT MTG. CIRCLE - SEE NOTES	CAST IRON	SEE NOTES	SEE NOTES
SERIES 903000 (HORIZONTAL 3.5 H.P.)																					
903400	30946	3/4"	2-27/64"	3/8-24 Tap, 3/16x1-7/8Kw	CS	2	FI	MB	Re					P	DS			3-5/8"	STD ■	✓	
903420	33028	5/8"	2-27/64"	5/16-24 Tap, 3/16x1-7/8Kw	CS	2	FI	MB	Re					P	DS			3-5/8"	STD ■	✓	

## NOTES

CS Carburetor side  
DS Dual sides oil drain  
FI Float carburetor

Kw Keyway  
MB Mini-Bike control  
P Paper air cleaner

Re Rewind starter  
STD Standard Engine  
■ This engine is not eligible for return.

# 3.5 HORSEPOWER (SMALL FRAME) TILLER APPLICATION

## STANDARD EQUIPMENT & DIMENSIONS

MODEL		H35
HORSEPOWER @ 3600 RPM		3.5
BORE & STROKE	INCHES	2-1/2 x 1-27/32
	MILLIMETERS	63.50 x 46.84
DISPLACEMENT	CUBIC INCHES	9.05
	CUBIC CENTIMETERS	148.34
LUBRICATION		Splash
GOVERNOR		Mechanical
OIL CAPACITY	OUNCES	21
	MILLILITERS	620
NET WEIGHT (APPROX.)	POUNDS	25
	KILOGRAMS	11.3
LENGTH "A" (IN INCHES)		17-1/8
HEIGHT "B" (IN INCHES)		13-43/64
WIDTH "C" (IN INCHES)		10-39/64
BOLT MTG. CIRCLE (IN INCHES)		3-5/8

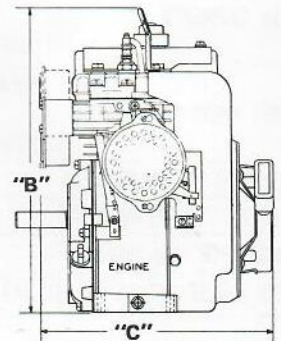
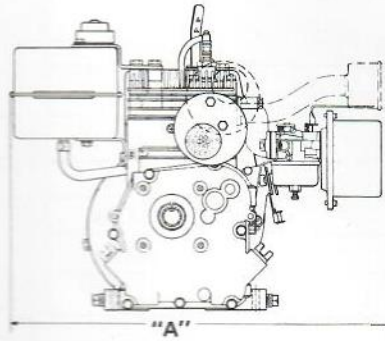
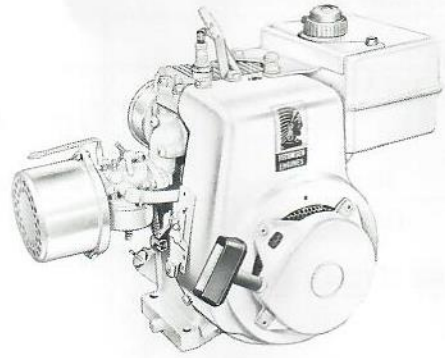

## ENGINE VARIATIONS

CRANKSHAFT				OTHER CRANKSHAFT SPECIFICATIONS	FUEL TANK CAPACITY IN QUARTS		PULSE TYPE FUEL PUMP	CARBURETOR	BALL BEARING CONTROLS	MAGNETO FEATURE STARTER	REGULATOR	AIR CLEANER	OIL FILLER TUBE	OIL DRAIN	BOLT MTG. CIRCLE - SEE NOTES	CAST IRON	FAST MOVING ENGINES SEE NOTES	
SERVICE NUMBER	PART NUMBER	DIAMETER	LENGTH		AUXILIARY P.T.O. SHAFT	EXHAUST DIRECTION												
Length of crankshaft is measured from drilled and tapped face on the cover plate to end of shaft.																		
SERIES 903000 (HORIZONTAL 3.5 H.P.)																		
903600	30878A	3/4"	2-29/64"	5/16-24 Tap, 3/16x1-7/8Kw Spotted	PS	2	FI	M	X	Re		P	DS			STD■	✓	
903603	30878A	3/4"	2-29/64"	5/16-24 Tap, 3/16x1-7/8Kw Spotted	CS	2	FI	R	X	Re		P	DS			STD■	✓	
903620A	30870A	5/8"	2-29/64"	5/16-24 Tap, 3/16x1-7/8Kw	CS	2	FI	M	X	Re		P	DS			STD■	✓	
903660	31274	3/4"	1-19/32"	3/16 x 1-1/64Kw	PS	4	FI	R	X	Re		F	DS			T‡	✓	

## NOTES

CS Carburetor side  
 DS Dual sides oil drain  
 F Poly foam air cleaner  
 FI Float carburetor  
 Kw Keyway

M Manual control  
 P Paper air cleaner  
 PS P.T.O. side  
 R Remote control  
 Re Rewind starter  
 S Side oil drain

STD Standard Engine  
 T Toro  
 ‡ This engine is not eligible for after-market O.E.M. Discount.  
 ■ This engine is not eligible for return.



# 4 HORSEPOWER (SMALL FRAME) INDUSTRIAL APPLICATION

## STANDARD EQUIPMENT & DIMENSIONS

MODEL	HS40	
HORSEPOWER @ 3600 RPM	4.0	
BORE & STROKE	INCHES	2-5/8 x 1-15/16
	MILLIMETERS	66.68 x 49.23
DISPLACEMENT	CUBIC INCHES	10.49
	CUBIC CENTIMETERS	171.91
LUBRICATION	Splash	
GOVERNOR	Mechanical	
OIL CAPACITY	OUNCES	21
	MILLILITERS	620
NET WEIGHT (APPROX.)	POUNDS	27
	KILOGRAMS	12.3
LENGTH "A" (IN INCHES)	16-29/32	
HEIGHT "B" (IN INCHES)	13-43/64	
WIDTH "C" (IN INCHES)	9-9/32	
BOLT MTG. CIRCLE (IN INCHES)	3-5/8	

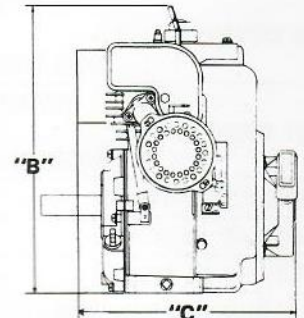
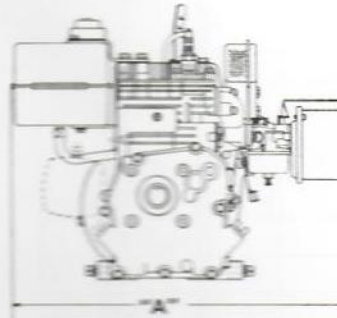
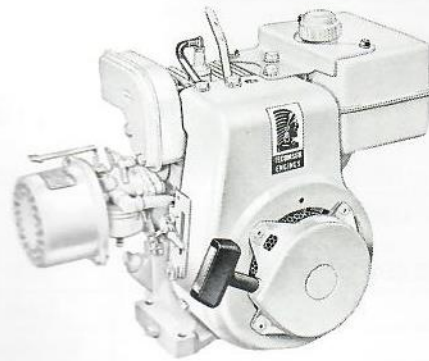

## ENGINE VARIATIONS

CRANKSHAFT				OTHER CRANKSHAFT SPECIFICATIONS	FUEL TANK CAPACITY IN QUARTS		CARBURETOR CONTROLS	BALL BEARING STARTER	MAGNETO FEATURE	AIR CLEANER REGULATOR	OIL FILLER TUBE	OIL DRAIN	BOLT MTG. CIRCLE - SEE NOTES	CAST IRON	FAST MOVING ENGINES SEE NOTES
LENGTH	DIAMETER	PART NUMBER	SERVICE NUMBER		AUXILIARY P.T.O. SHAFT	EXHAUST DIRECTION									
SERIES 904000 (HORIZONTAL 4.0 H.P.)															
2-27/64"	3/4"	32877	904210	3/8-24 Tap, 3/16x1-7/8Kw	CS	2	FI	M	Re		P	DS		STD	✓

## NOTES

CS Carburetor side  
DS Dual sides oil drain  
FI Float carburetor

Kw Keyway  
M Manual control  
P Paper air cleaner

Re Rewind starter  
STD Standard Engine  
■ This engine is not eligible for return.

# 4 HORSEPOWER (SMALL FRAME) MINI BIKE APPLICATION

## STANDARD EQUIPMENT & DIMENSIONS

MODEL		HS40
HORSEPOWER @ 3600 RPM		4.0
BORE & STROKE	INCHES	2-5/8 x 1-15/16
	MILLIMETERS	66.68 x 49.23
DISPLACEMENT	CUBIC INCHES	10.49
	CUBIC CENTIMETERS	171.91
LUBRICATION		Splash
GOVERNOR		Mechanical
OIL CAPACITY	OUNCES	21
	MILLILITERS	620
NET WEIGHT (APPROX.)	POUNDS	27
	KILOGRAMS	12.3
LENGTH "A" (IN INCHES)		17-13/64
HEIGHT "B" (IN INCHES)		13-43/64
WIDTH "C" (IN INCHES)		9-9/32
BOLT MTG. CIRCLE (IN INCHES)		3-5/8

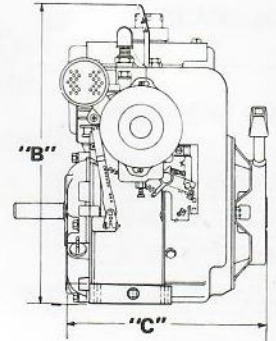
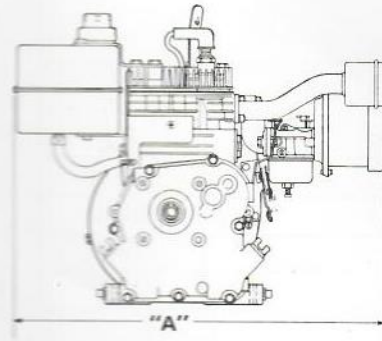
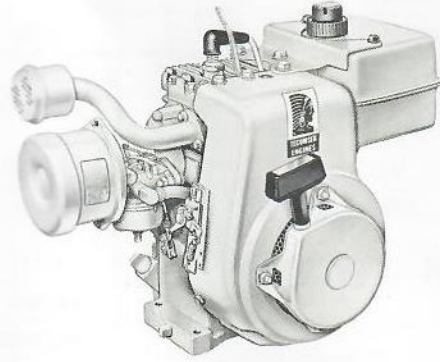

## ENGINE VARIATIONS

CRANKSHAFT				OTHER CRANKSHAFT SPECIFICATIONS	VARIATION FEATURES										FAST MOVING ENGINES SEE NOTES				
SERVICE NUMBER	PART NUMBER	DIAMETER	LENGTH		FUEL TANK CAPACITY IN QUARTS	PULSE TYPE FUEL PUMP	EXHAUST DIRECTION	AUXILIARY P.T.O. SHAFT	CARBURETOR	CONTROLS	BALL BEARING	MAGNETO FEATURE	STARTER	REGULATOR		AIR CLEANER	OIL FILLER TUBE	BOLT MTG. CIRCLE - SEE NOTES	CAST IRON
Length of crankshaft is measured from drilled and tapped face on the cover plate to end of shaft.																			
SERIES 904000 (HORIZONTAL 4.0 H.P.)																			
904400A	32877A	3/4"	2-27/64"	3/8-24 Tap, 3/16x1-7/8Kw Spotted	CS	2	FI	MB	Re				P	DS				STD■	✓
904403	32877A	3/4"	2-27/64"	3/8-24 Tap, 3/16x1-17/8Kw Spotted	CS	2	FI	MB	Re	3amp			P	DS				STD■	✓

## NOTES

CS Carburetor side  
DS Dual sides oil drain  
FI Float carburetor

Kw Keyway  
MB Mini-Bike control  
P Paper air cleaner

Re Rewind starter  
STD Standard Engine  
■ This engine is not eligible for return.

# 4 HORSEPOWER (SMALL FRAME) MINI BIKE APPLICATION (20° SLANT)

## STANDARD EQUIPMENT & DIMENSIONS

<b>MODEL</b>	<b>HS40</b>
<b>HORSEPOWER @ 3600 RPM</b>	<b>4.0</b>
<b>BORE &amp; STROKE</b>	<b>2-5/8 x 1-15/16</b>
<b>INCHES</b>	
<b>MILLIMETERS</b>	<b>66.68 x 49.23</b>
<b>DISPLACEMENT</b>	<b>10.49</b>
<b>CUBIC INCHES</b>	
<b>CUBIC CENTIMETERS</b>	<b>171.91</b>
<b>LUBRICATION</b>	<b>Splash</b>
<b>GOVERNOR</b>	<b>Mechanical</b>
<b>OIL CAPACITY</b>	<b>21</b>
<b>OUNCES</b>	
<b>MILLILITERS</b>	<b>620</b>
<b>NET WEIGHT (APPROX.)</b>	<b>26</b>
<b>POUNDS</b>	
<b>KILOGRAMS</b>	<b>11.8</b>
<b>LENGTH "A" (IN INCHES)</b>	<b>15-43/64</b>
<b>HEIGHT "B" (IN INCHES)</b>	<b>13-43/64</b>
<b>WIDTH "C" (IN INCHES)</b>	<b>9-15/16</b>
<b>BOLT MTG. CIRCLE (IN INCHES)</b>	<b>3-5/8</b>

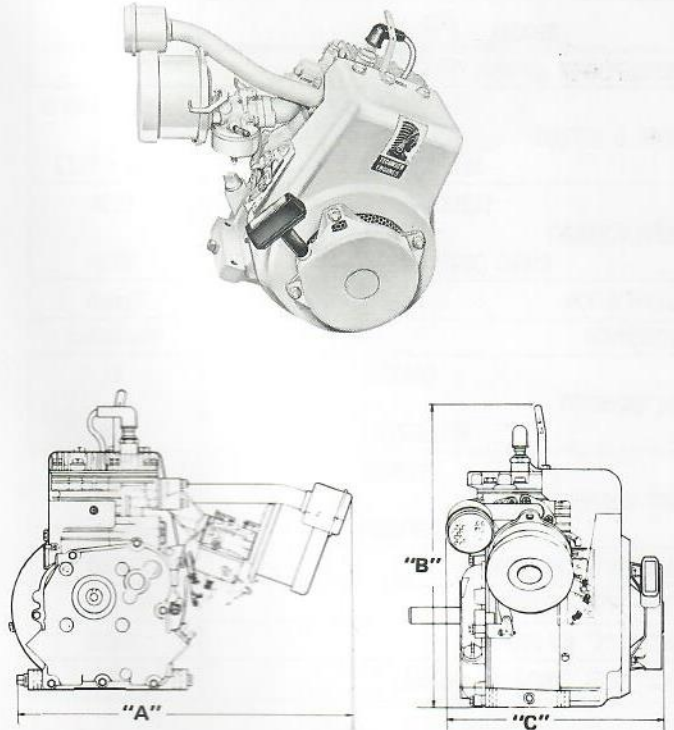

## ENGINE VARIATIONS

CRANKSHAFT				OTHER CRANKSHAFT SPECIFICATIONS														FAST MOVING ENGINES	
SERVICE NUMBER	PART NUMBER	DIAMETER	LENGTH	CRANKSHAFT SPECIFICATIONS														FAST MOVING ENGINES	
				FUEL TANK CAPACITY IN QUARTS	PULSE TYPE FUEL PUMP	CARBURETOR	BALL BEARING	MAGNETO FEATURE	OIL FILLER TUBE	BOLT MTG. CIRCLE - SEE NOTES	FAST MOVING ENGINES								
Length of crankshaft is measured from drilled and tapped face on the cover plate to end of shaft.				AUXILIARY P.T.O. SHAFT	EXHAUST DIRECTION	CONTROL	STARTER	REGULATOR	AIR CLEANER	OIL DRAIN	CAST IRON	SEE NOTES	SEE NOTES	SEE NOTES	SEE NOTES	SEE NOTES	SEE NOTES		
SERIES 904000 (HORIZONTAL 4.0 H.P.)																			
904413	33080	3/4"	3"	3/8-24 Tap, 3/16x2-3/8Kw	CS		FI	MB	X	Re	3amp	P	DS			STD	✓		

## NOTES

CS Carburetor side  
DS Dual sides oil drain  
FI Float carburetor

Kw Keyway  
MB Mini-Bike control  
P Paper air cleaner

Re Rewind starter  
STD Standard Engine  
■ This engine is not eligible for return.

# 5 HORSEPOWER (SMALL FRAME) INDUSTRIAL APPLICATION

## STANDARD EQUIPMENT & DIMENSIONS

MODEL		HS50
HORSEPOWER @ 3600 RPM		5.0
BORE & STROKE	INCHES	2-13/16 x 1-15/16
	MILLIMETERS	71.44 x 49.23
DISPLACEMENT	CUBIC INCHES	12.04
	CUBIC CENTIMETERS	197.34
LUBRICATION		Splash
GOVERNOR		Mechanical
OIL CAPACITY	OUNCES	21
	MILLILITERS	620
NET WEIGHT (APPROX.)	POUNDS	28
	KILOGRAMS	12.7
LENGTH "A" (IN INCHES)		17-1/8
HEIGHT "B" (IN INCHES)		13-13/16
WIDTH "C" (IN INCHES)		9-5/16
BOLT MTG. CIRCLE (IN INCHES)		3-5/8

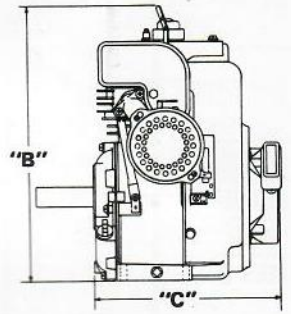
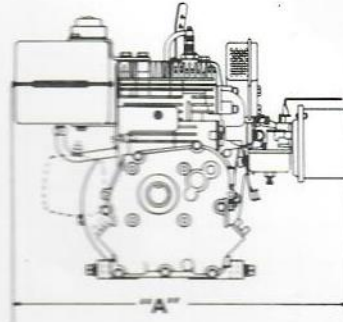
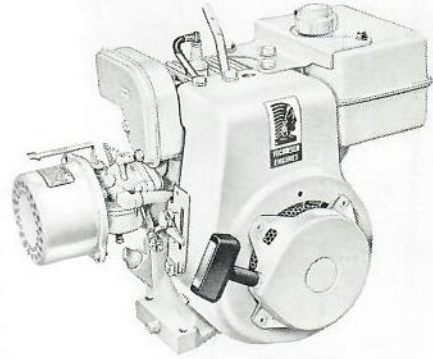

## ENGINE VARIATIONS

CRANKSHAFT				OTHER CRANKSHAFT SPECIFICATIONS	FUEL TANK CAPACITY IN QUARTS	PULSE TYPE FUEL INJECTORS	EXHAUST DIRECTION	AUXILIARY P.T.O. SHAFT	CARBURETOR	BALL BEARING CONTROLS	MAGNETO FEATURE	STARTER	OIL FILLER TUBE	AIR CLEANER	REGULATOR	OIL DRAIN	OIL FILLER TUBE	CAST IRON	BOLT MTG. CIRCLE - SEE NOTES	SEE NOTES	FAST MOVING ENGINES
SERVICE NUMBER	PART NUMBER	DIAMETER	LENGTH																		
Length of crankshaft is measured from drilled and tapped face on the cover plate to end of shaft.																					
SERIES 905000 (HORIZONTAL 5.0 H.P.)																					
905200	34117	5/8"	2-7/16"	5/8-18 Thread	CS	2	FI	M	X	Re			P	DS					STD	■	
905210	34022	3/4"	2-27/32"	5/16-24 Tap, Tapered	CS	2	FI	FS	X	Re			P	DS					STD	■	✓

## NOTES

CS Carburetor side  
DS Dual sides oil drain  
FI Float carburetor

FS Fixed speed  
M Manual control  
P Paper air cleaner

Re Rewind starter  
STD Standard Engine  
■ This engine is not eligible for return.

# 5 HORSEPOWER (MEDIUM FRAME) INDUSTRIAL APPLICATION

## STANDARD EQUIPMENT & DIMENSIONS

MODEL	H50	HH50 CAST IRON
HORSEPOWER @ 3600 RPM	5.0	5.0
BORE & STROKE	INCHES	2-5/8 x 2-1/4
	MILLIMETERS	66.68 x 57.15
DISPLACEMENT	CUBIC INCHES	12.21
	CUBIC CENTIMETERS	199.38
LUBRICATION	Splash	Splash
GOVERNOR	Mechanical	Mechanical
OIL CAPACITY	OUNCES	19
	MILLILITERS	560
NET WEIGHT (APPROX.)	POUNDS	39
	KILOGRAMS	17.7
LENGTH "A" (IN INCHES)	18-15/32	18-15/32
HEIGHT "B" (IN INCHES)	15-31/32	15-31/32
WIDTH "C" (IN INCHES)	13-3/4	13-3/4
BOLT MTG. CIRCLE (IN INCHES)	3-5/8	3-5/8

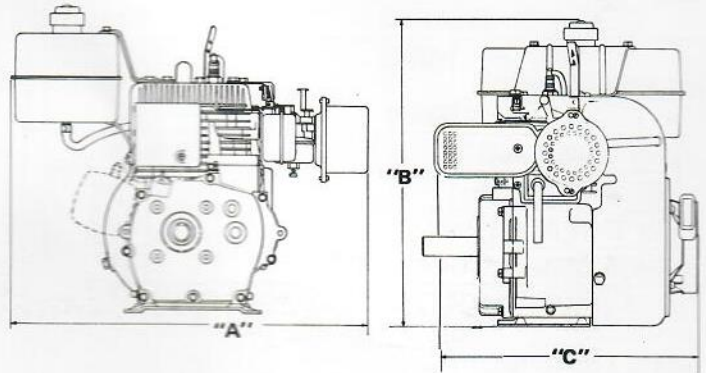
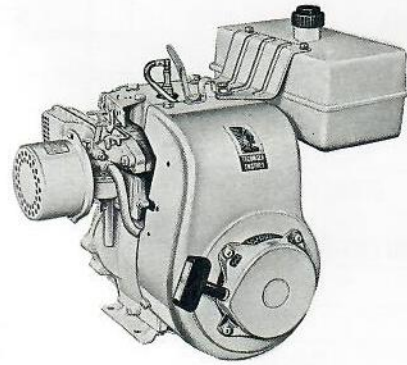

## ENGINE VARIATIONS

CRANKSHAFT				OTHER CRANKSHAFT SPECIFICATIONS	FUEL TANK CAPACITY IN QUARTS	PULSE TYPE FUEL PUMP	EXHAUST DIRECTION	AUXILIARY P.T.O. SHAFT	CARBURETOR	BALL BEARING	MAGNETO FEATURE	STARTER	REGULATOR	AIR CLEANER	OIL FILLER TUBE	OIL DRAIN	BOLT MTG. CIRCLE - SEE NOTES	CAST IRON	FAST MOVING ENGINES SEE NOTES
SERVICE NUMBER	PART NUMBER	DIAMETER	LENGTH																
Length of crankshaft is measured from drilled and tapped face on the cover plate to end of shaft.																			
SERIES 905000 (HORIZONTAL 5.0 H.P.)																			
905220	31826	3/4"	2-13/32"	3/8-24 Tap, 3/16x1-7/8Kw	CS	4	PP	FI	R	X	Re			P	DS	X			STD 2,5
905230	32034	25/32"	2-55/64"	5/16-24 Tapered	CS	4		FI	FS	X	Re			P	DS				STD 2,5
905240	32111	3/4"	2-63/64"	3/4-16 Thread	CS	4		FI	M	X	Re			P	X	DS			STD 2,5

## NOTES

CS Carburetor side  
DS Dual sides oil drain  
FI Float carburetor  
FS Fixed speed  
Kw Keyway  
M Manual control

P Paper air cleaner  
PP Provision for pulse type fuel pump  
R Remote control  
Re Rewind starter  
STD Standard Engine  
■ This engine is not eligible for return.

2 No. 28975 - 12 Volt Electric Starter and 32158C Blower Housing can be installed.  
5 No. 33328A - 120 Volt Electric Starter 30811A Flywheel and 32158C Blower Housing can be installed.

# 5 HORSEPOWER (SMALL FRAME) SNOW KING APPLICATION

## STANDARD EQUIPMENT & DIMENSIONS

MODEL	HS50	
HORSEPOWER @ 3600 RPM	5.0	
BORE & STROKE	INCHES	2-13/16 x 1-15/16
	MILLIMETERS	71.44 x 49.23
DISPLACEMENT	CUBIC INCHES	12.04
	CUBIC CENTIMETERS	197.34
LUBRICATION	Splash	
GOVERNOR	Mechanical	
OIL CAPACITY	OUNCES	21
	MILLILITERS	620
NET WEIGHT (APPROX.)	POUNDS	29
	KILOGRAMS	13.2
LENGTH "A" (IN INCHES)	15-15/32	
HEIGHT "B" (IN INCHES)	13-21/64	
WIDTH "C" (IN INCHES)	9-9/32	
BOLT MTG. CIRCLE (IN INCHES)	3-5/8	

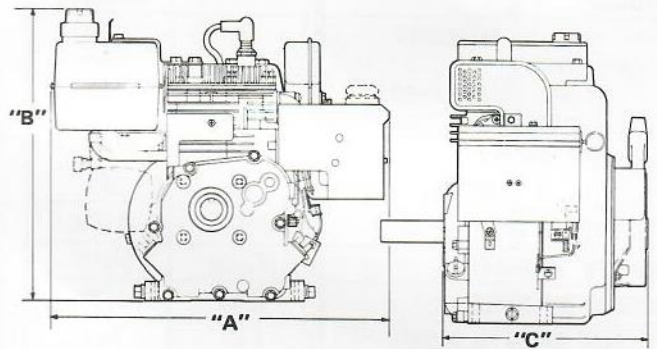
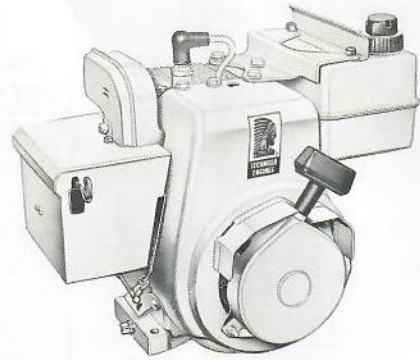

## ENGINE VARIATIONS

CRANKSHAFT				OTHER CRANKSHAFT SPECIFICATIONS	AUXILIARY P.T.D. SHAFT	FUEL TANK CAPACITY IN QUARTS	EXHAUST DIRECTION	PULSE TYPE FUEL PUMP	CARBURETOR CONTROLS	BALL BEARING STARTER	MAGNETO FEATURE	REGULATOR AIR CLEANER	OIL FILLER TUBE OIL DRAIN	BOLT MTG. CIRCLE - SEE NOTES	CAST IRON	FAST MOVING ENGINES	
SERVICE NUMBER	PART NUMBER	DIAMETER	LENGTH														
Length of crankshaft is measured from drilled and tapped face on the cover plate to end of shaft.																	
SERIES 905000 (HORIZONTAL 5.0 H.P.)																	
905300A	33677A	3/4"	2-27/64"	3/8-24 Tap, 3/16x1-7/8Kw, Spotted	2:1	CS	2	FI	M		Re				DS		STD ■ 9 ✓

## NOTES

CS Carburetor side  
 DS Dual sides oil drain  
 FI Float carburetor  
 Kw Keyway

M Manual control  
 Re Rewind starter  
 STD Standard Engine

■ This engine is not eligible for return.  
 9 No. 33290A - 120 Volt Electric Starter can be installed.

# 5 HORSEPOWER (SMALL FRAME) MINI BIKE APPLICATION

## STANDARD EQUIPMENT & DIMENSIONS

MODEL	HS50
HORSEPOWER @ 3600 RPM	5.0
BORE & STROKE INCHES	2-13/16 x 1-15/16
MILLIMETERS	71.44 x 49.23
DISPLACEMENT CUBIC INCHES	12.04
CUBIC CENTIMETERS	197.34
LUBRICATION	Splash
GOVERNOR	Mechanical
OIL CAPACITY OUNCES	21
MILLILITERS	620
NET WEIGHT (APPROX.) POUNDS	28
KILOGRAMS	12.7
LENGTH "A" (IN INCHES)	17-7/16
HEIGHT "B" (IN INCHES)	13-13/16
WIDTH "C" (IN INCHES)	9-9/32
BOLT MTG. CIRCLE (IN INCHES)	3-5/8

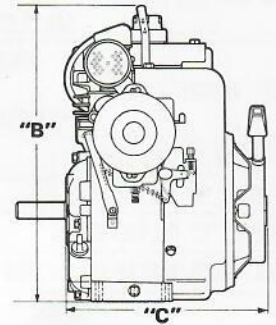
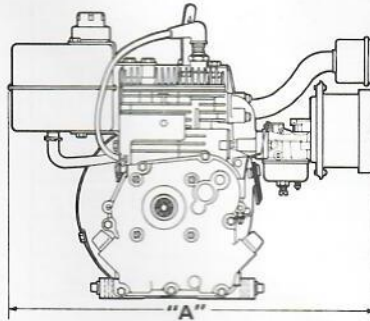
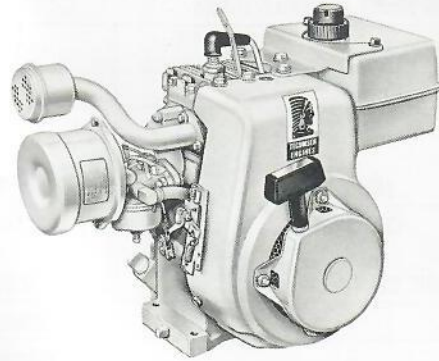

## ENGINE VARIATIONS

CRANKSHAFT					OTHER CRANKSHAFT SPECIFICATIONS																
Length of crankshaft is measured from drilled and tapped face on the cover plate to end of shaft.					AUXILIARY P.T.O. SHAFT	FUEL TANK CAPACITY IN QUARTS	PULSE TYPE FUEL PUMP	EXHAUST DIRECTION	CARBURETOR	BALL BEARING	STARTER	MAGNETO FEATURE	REGULATOR	AIR CLEANER	OIL FILLER TUBE	OIL DRAIN	BOLT MTG. CIRCLE - SEE NOTES	CAST IRON	FAST MOVING ENGINES		
SERVICE NUMBER	PART NUMBER	DIAMETER	LENGTH	OTHER CRANKSHAFT SPECIFICATIONS																	
SERIES 905000 (HORIZONTAL 5.0 H.P.)																					
905410	33676	3/4"	2-27/64"	3/8-24 Tap, 3/16x1-7/8Kw		CS	2	FI	MB	X	Re			P	DS			STD	/		

## NOTES

CS Carburetor side  
DS Dual sides oil drain  
FI Float carburetor

Kw Keyway  
MB Mini-Bike control  
P Paper air cleaner

Re Rewind starter  
STD Standard Engine  
■ This engine is not eligible for return.

# 5 HORSEPOWER (SMALL FRAME) MINI BIKE APPLICATION (20° SLANT)

## STANDARD EQUIPMENT & DIMENSIONS

MODEL	HS50
HORSEPOWER @ 3600 RPM	5.0
BORE & STROKE INCHES	2-13/16 x 1-15/16
MILLIMETERS	71.44 x 49.23
DISPLACEMENT CUBIC INCHES	12.04
CUBIC CENTIMETERS	197.34
LUBRICATION	Splash
GOVERNOR	Mechanical
OIL CAPACITY OUNCES	21
MILLILITERS	620
NET WEIGHT (APPROX.) POUNDS	28
KILOGRAMS	12.7
LENGTH "A" (IN INCHES)	15-43/64
HEIGHT "B" (IN INCHES)	13-43/64
WIDTH "C" (IN INCHES)	10-11/16
BOLT MTG. CIRCLE (IN INCHES)	3-5/8

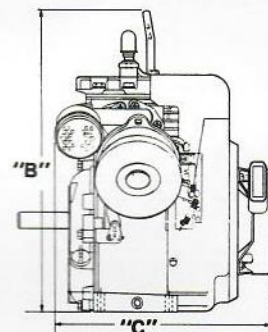
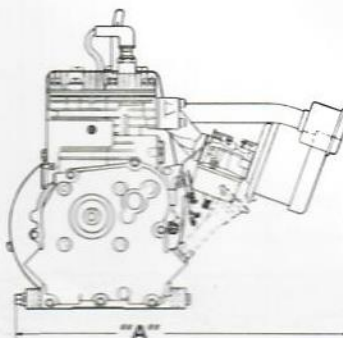
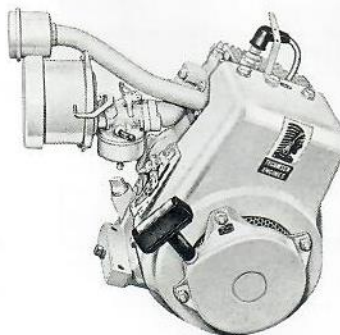

## ENGINE VARIATIONS

CRANKSHAFT Length of crankshaft is measured from drilled and tapped face on the cover plate to end of shaft.				OTHER CRANKSHAFT SPECIFICATIONS	FUEL TANK CAPACITY IN QUARTS		PULSE TYPE FUEL PUMP		EXHAUST DIRECTION		AUXILIARY P.T.O. SHAFT		CARBURETOR		BALL BEARING CONTROLS		MAGNETO FEATURE		STARTER		AIR CLEANER REGULATOR		OIL FILLER TUBE		OIL DRAIN		BOLT MTG. CIRCLE - SEE NOTES		CAST IRON		FAST MOVING ENGINES		
SERVICE NUMBER	PART NUMBER	DIAMETER	LENGTH		FUEL TANK CAPACITY IN QUARTS	PULSE TYPE FUEL PUMP	EXHAUST DIRECTION	AUXILIARY P.T.O. SHAFT	CARBURETOR	BALL BEARING CONTROLS	MAGNETO FEATURE	STARTER	AIR CLEANER REGULATOR	OIL FILLER TUBE	OIL DRAIN	BOLT MTG. CIRCLE - SEE NOTES	CAST IRON	FAST MOVING ENGINES															
SERIES 905000 (HORIZONTAL 5.0 H.P.)																		3amp		P		DS		STD									
905420	33676	3/4"	2-27/64"	3/8-24 Tap, 3/16x1-7/8Kw	CS	FI	MB	X	Re																								

## NOTES

CS Carburetor side  
DS Dual sides oil drain  
FI Float carburetor

Kw Keyway  
MB Mini-Bike control  
P Paper air cleaner

Re Rewind starter  
STD Standard Engine  
■ This engine is not eligible for return.



# 5 HORSEPOWER (SMALL FRAME) TILLER APPLICATION

## STANDARD EQUIPMENT & DIMENSIONS

MODEL	HS50	
HORSEPOWER @ 3600 RPM	5.0	
BORE & STROKE	INCHES	2-13/16 x 1-15/16
	MILLIMETERS	71.44 x 49.23
DISPLACEMENT	CUBIC INCHES	12.04
	CUBIC CENTIMETERS	197.34
LUBRICATION	Splash	
GOVERNOR	Mechanical	
OIL CAPACITY	OUNCES	21
	MILLILITERS	620
NET WEIGHT (APPROX.)	POUNDS	28
	KILOGRAMS	12.7
LENGTH "A" (IN INCHES)	17-1/8	
HEIGHT "B" (IN INCHES)	13-13/16	
WIDTH "C" (IN INCHES)	9-5/16	
BOLT MTG. CIRCLE (IN INCHES)	3-5/8	

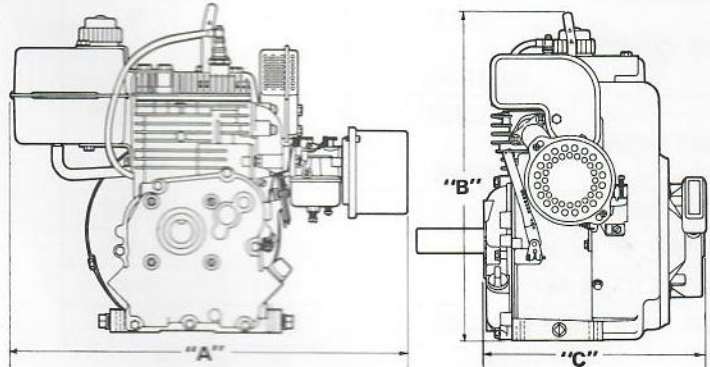
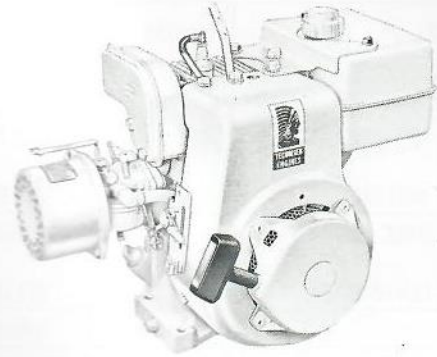

## ENGINE VARIATIONS

CRANKSHAFT				OTHER CRANKSHAFT SPECIFICATIONS	AUXILIARY P.T.O. SHAFT	FUEL TANK CAPACITY IN QUARTS	PULSE TYPE FUEL PUMP	EXHAUST DIRECTION	CARBURETOR	BALL BEARING CONTROLS	MAGNETO FEATURE	STARTER	OIL FILLER TUBE	AIR CLEANER	REGULATOR	OIL DRAIN	BOLT MTG. CIRCLE - SEE NOTES	CAST IRON	FAST MOVING ENGINES	
SERVICE NUMBER	PART NUMBER	DIAMETER	LENGTH																	
Length of crankshaft is measured from drilled and tapped face on the cover plate to end of shaft.																				
SERIES 905000 (HORIZONTAL 5.0 H.P.)																				
905600A	33677A	3/4"	2-27/64"	3/8-24 Tap, 3/16x1-7/8Kw Spotted	2:1	CS	2	FI	R		Re		P	DS				STD	✓	

## NOTES

CS Carburetor side  
DS Dual sides oil drain  
FI Float carburetor

Kw Keyway  
P Paper air cleaner  
R Remote control

Re Rewind starter  
STD Standard Engine  
■ This engine is not eligible for return.

# 6 HORSEPOWER (MEDIUM FRAME) INDUSTRIAL APPLICATION

## STANDARD EQUIPMENT & DIMENSIONS

MODEL	H60	HH60 CAST IRON
HORSEPOWER @ 3600 RPM	6.0	6.0
BORE & STROKE INCHES	2-5/8 x 2-1/2	2-5/8 x 2-1/2
MILLIMETERS	66.68 x 63.50	66.68 x 63.50
DISPLACEMENT CUBIC INCHES	13.53	13.53
CUBIC CENTIMETERS	221.75	221.75
LUBRICATION	Splash	Splash
GOVERNOR	Mechanical	Mechanical
OIL CAPACITY OUNCES	19	19
MILLILITERS	560	560
NET WEIGHT (APPROX.) POUNDS	39	60
KILOGRAMS	17.7	27.2
LENGTH "A" (IN INCHES)	18-15/32	18-15/32
HEIGHT "B" (IN INCHES)	15-31/32	15-31/32
WIDTH "C" (IN INCHES)	13-3/4	13-3/4
BOLT MTG. CIRCLE (IN INCHES)	3-5/8	3-5/8

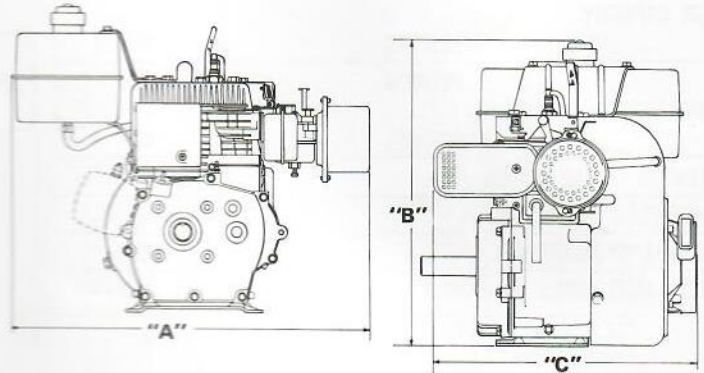

## ENGINE VARIATIONS

CRANKSHAFT				OTHER CRANKSHAFT SPECIFICATIONS	FUEL TANK CAPACITY IN QUARTS	PULSE TYPE FUEL PUMP	EXHAUST DIRECTION	AUXILIARY P.T.O. SHAFT	CARBURETOR	BALL BEARING	MAGNETO FEATURE	STARTER	REGULATOR	AIR CLEANER	OIL FILLER TUBE	OIL DRAIN	BOLT MTG. CIRCLE - SEE NOTES	CAST IRON	FAST MOVING ENGINES SEE NOTES
SERVICE NUMBER	PART NUMBER	DIAMETER	LENGTH																
Length of crankshaft is measured from drilled and tapped face on the cover plate to end of shaft.																			
SERIES 906000 (HORIZONTAL 6.0 H.P.)																			
906200	31827	3/4"	2-13/32"	3/8-24 Tap, 3/16x1-7/8Kw	CS	4	PP	FI	R-M	X	Re			P	DS			STD■2,5	✓
906203	31827	3/4"	2-13/32"	3/8-24, Tap, 3/16x1-7/8Kw	CS	4	PP	FI	R-M	X	E-Re	3amp		P	DS			STD■	✓
906210A	30799	1"	2-15/16"	3/8-24 Tap, 1/4 x 2-3/8Kw	CS	4	PP	FI	R		Re			P	X	DS		STD■2,5	✓
906213	31791	1"	2-15/16"	3/8-24 Tap, 1/4 x 2-3/8Kw	CS	4	PP	FI	R-M	X	Re			P	DS	X		STD■2,5	
906220	31860	3/4"	2-63/64"	3/4-16 Thread	CS	4	PP	FI	M	X	Re			P	DS	X		STD■2,5	

## NOTES

CS	Carburetor side	P	Paper air cleaner	2	No. 28975 - 12 Volt Electric Starter and 32158C Blower Housing can be installed.
DS	Dual sides oil drain	PP	Provision for pulse fuel pump		
E	Electric starter	R	Remote control		
FI	Float carburetor	Re	Rewind starter	5	No. 33328A - 120 Volt Electric Starter 30811A Flywheel and 32158C Blower Housing can be installed.
Kw	Keyway	STD	Standard Engine		
M	Manual control	■	This engine is not eligible for return.		

# 6 HORSEPOWER (MEDIUM FRAME) TILLER APPLICATION

## STANDARD EQUIPMENT & DIMENSIONS

MODEL	H60	HH60 CAST IRON
HORSEPOWER @ 3600 RPM	6.0	6.0
BORE & STROKE INCHES	2-5/8 x 2-1/2	2-5/8 x 2-1/2
MILLIMETERS	66.68 x 63.50	66.68 x 63.50
DISPLACEMENT CUBIC INCHES	13.53	13.53
CUBIC CENTIMETERS	221.75	221.75
LUBRICATION	Splash	Splash
GOVERNOR	Mechanical	Mechanical
OIL CAPACITY OUNCES	19	19
MILLILITERS	560	560
NET WEIGHT (APPROX.) POUNDS	39	60
KILOGRAMS	17.7	27.2
LENGTH "A" (IN INCHES)	18-15/32	18-15/32
HEIGHT "B" (IN INCHES)	15-31/32	15-31/32
WIDTH "C" (IN INCHES)	13-3/4	13-3/4
BOLT MTG. CIRCLE (IN INCHES)	3-5/8	3-5/8

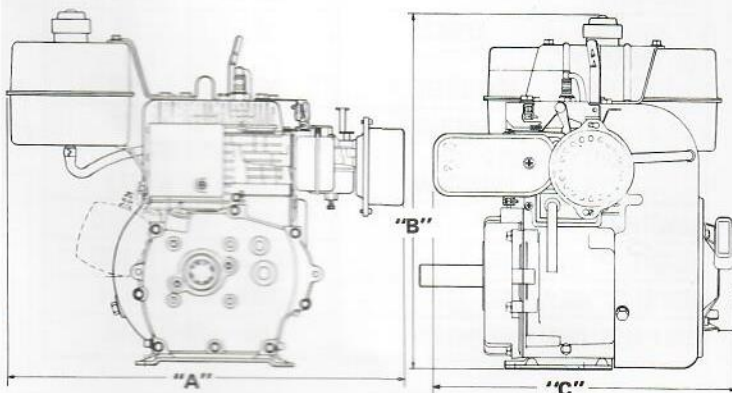

## ENGINE VARIATIONS

CRANKSHAFT				OTHER CRANKSHAFT SPECIFICATIONS	AUXILIARY P.T.O. SHAFT	FUEL TANK CAPACITY IN QUARTS	PULSE TYPE FUEL PUMP	CARBURETOR	CONTROLS	BALL BEARING	MAGNETO FEATURE	STARTER	AIR CLEANER	REGULATOR	OIL FILLER TUBE	OIL DRAIN	BOLT MTG. CIRCLE - SEE NOTES	CAST IRON	FAST MOVING ENGINES	
SERVICE NUMBER	PART NUMBER	DIAMETER	LENGTH																	
Length of crankshaft is measured from drilled and tapped face on the cover plate to end of shaft.																				
SERIES 906000 (HORIZONTAL 6.0 H.P.)																				
906661	31856A	3/4"	2-13/32"	3/8-24 Tap, 3/16x1-7/8Kw spotted (2)	2:1	CS	4	FI	R		Re		F	DS					STD■2,5	
906663A	31824	3/4"	2-13/32"	3/8-24 Tap, 3/16x1-7/8Kw		CS	6	FI	R		Re		F	DS	X				GW‡ 3	✓

## NOTES

CS Carburetor side  
 DS Dual sides oil drain  
 F Poly foam air cleaner  
 FI Float carburetor  
 GW Gardenway  
 Kw Keyway  
 R Remote control



Re Rewind starter  
 STD Standard Engine  
 ‡ This engine is not eligible for after-market O.E.M. Discount.  
 ■ This engine is not eligible for return.  
 2 No. 28975 - 12 Volt Electric Starter and 32158C Blower Housing can be installed.







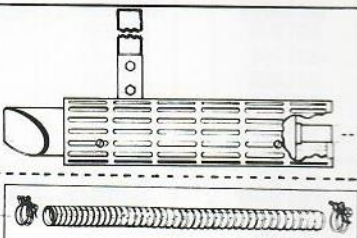

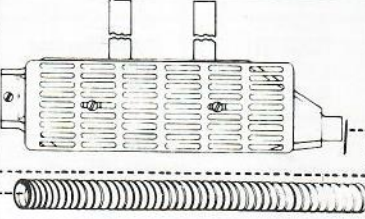
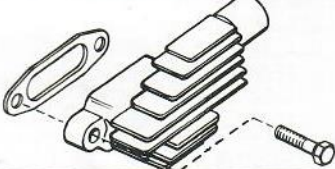
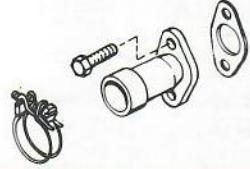
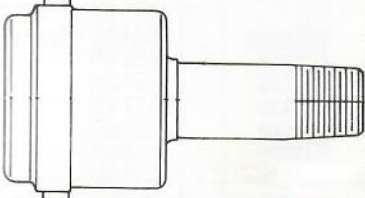
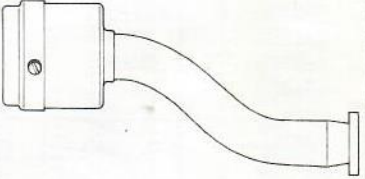
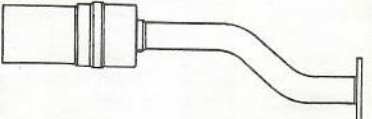
3 No. 28975 - 12 Volt Electric Starter can be installed.  
 5 No. 33328A - 120 Volt Electric Starter 3811A Flywheel and 32158C Blower Housing can be installed.

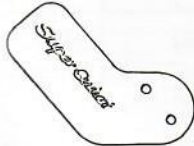
# ACCESSORIES

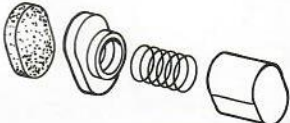
Accessories such as 12 volt and 120 volt electric starters are listed in the "NOTES" column against specific replacement engines. These "NOTES" are explained at the end of the specifications.

Other accessories which are available are listed as follows:

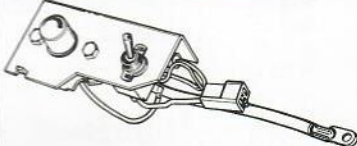
PART NO.	DESCRIPTION	APPLICATION	
730522	Muffler Kit, Deluxe Mini-bike	3.5-4 H.P. Mini-bike (add 33716 adapter for HS50 Mini-bike)	
33514	Tube & Clamp Kit	Tube & Clamp Kit NOT included in 730522. Order separately	
33716	Muffler Adapter	Required to install 730522 on HS50 Mini-bike Engines	
730524	Muffler Kit, Deluxe Series	(add 391011 adapter for H35, HS40 Engines) (add 391013 adapter for HS50 Engines) (add 391012 adapter for H60, H70 Engines) (add 390293 adapter for 2 cycle Engines)	
390293	Muffler Adapter	2 cycle Mini-bike	
391011	Muffler Adapter	Required to install 730524 on H35 & HS40 Engines Required to install 730524 on H60, H70 Engines Required to install 730524 on HS50 Engines	
391012	Muffler Adapter		
391013	Muffler Adapter		
33288	Muffler, Chrome Spark Arrester	Screw-in type 4 H.P. (requires 30617 elbow and 27675 conduit nut)	
33126A	Muffler, Chrome Spark Arrester	3.5 H.P. Mini-bike	
33128A	Muffler, Chrome Spark Arrester	4 H.P. Mini-bike	
33224	Muffler, Chrome Spark Arrester	4 H.P. Mini-bike, 20° slant	
33699	Muffler, Spark Arrester	HS50 Mini-bike	

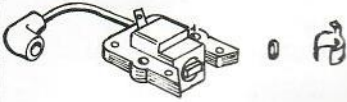
PART NO.	DESCRIPTION	APPLICATION	
391003	Muffler, Super Quiet	4 H.P. vertical crankshaft model. LAV40 Industrial Appl.	
391004	Muffler, Super Quiet	3.5 H.P. & 4 H.P. Vertical crankshaft model. (4 H.P. Rotary Mowers-check exhaust position)	
391009	Muffler, Tractor	12 - 16 H.P. Horizontal crankshaft models	
391010	Muffler, Tractor	6-10 H.P. Horizontal crankshaft models	
730510	Pre-cleaner	2 cycle vertical	
730512	Pre-cleaner	6 & 7 H.P.	
29553A 31573A 32437A	Gauge, Fuel (3.44" long) Gauge, Fuel (4.50" long) Gauge, Fuel (5.25" long)		
28607	Indicator, Oil level	3.5 - 7 H.P. vertical crankshaft models which do not have dipsticks.	
730198	Panel, Switch	All models with 20 amp system	
34279A	Filter, Fuel	For all engines	
730207	Solid State Conversion Kit	For all models TVS90, TVS105, TNT100, TNT120 & LAV50 engines with external magneto ignition.	

**CROSS REFERENCE LIST**

NEW SERVICE NUMBER	OLD SERVICE NUMBER	NEW SERVICE NUMBER	OLD SERVICE NUMBER	OLD SERVICE NUMBER	NEW SERVICE NUMBER	OLD SERVICE NUMBER	NEW SERVICE NUMBER
800100	710330C	808763	752214	710235A	800130	752170	807761
800110	710274C	808764	752226	710274C	800110	752171	807763
800120	710277C	900260	710376	710277C	800120	752185	807703
800130	710235A	900261	710336	710312C	800140	752186A	807762
800140	710312C	900262	710342A	710324B	900360	752202A	808700
800200	710354B	900360	710324B	710327	900365	752203	806764
800203	710355B	900361	710350	710330C	800100	752204	806765
803100	750175B	900362	710391	710334	900366	752205	808760
803103	750179C	900363	710341	710335A	900367	752206A	808761
803105	750210B	900364	710383	710336	900261	752213	808762
803110	750170A	900365	710327	710341	900363	752214	808763
803120	750200A	900366	710334	710342A	900262	752226	808764
803160	750227A	900367	710335A	710350	900361	752228	806161
803161	750229A	900400	710382	710354B	800200	752231	806767
803162	750249	900403	710386	710355B	800203	752232	807766
803163	750228A	903200	754131	710376	900260	754103	903660
803164	750165A	903360	754109A	710382	900400	754109A	903360
803165	750230A	903400	754174	710383	900364	754115A	903603
803166	750248	903410	754181	710386	900403	754123	903630
803167	750166A	903420	754164A	710391	900362	754131	903200
803168	750335	903423	754150A	750152A	803170	754137	903600
803169	750154	903430	754180	750154	803169	754138	903620
803170	750152A	903600	754137	750165A	803164	754141	903610
803171	750250	903603	754115A	750166A	803167	754150A	903423
803172	750235	903610	754141	750170A	803110	754154A	904600
803173	750334	903620	754138	750174A	804110	754161A	904300
803200	750260A	903630	754123	750175B	803100	754164A	903420
804100	750207A	903660	754103	750179C	803103	754165	904200
804110	750174A	903661	754172	750200A	803120	754167	904400
804120	750211	904200	754165	750207A	804100	754168	904403
804130	750313	904300	754161A	750210B	803105	754172	903661
804160	750296A	904400	754167	750211	804120	754174	903400
804161	750295	904403	754168	750227A	803160	754180	903430
804162	750331	904410	754183	750228A	803163	754181	903410
804163	750274	904413	754182	750229A	803161	754182	904413
805160	750298A	904600	754154A	750230A	803165	754183	904410
805161	750297	905300	754196	750235	803172	754190	905410
805162	750332	905410	754190	750248	803166	754193	905420
805163	750333	905420	754193	750249	803162	754194	905600
805760	750275A	905600	754194	750250	803171	754196	905300
806160	752103A	906200	756141	750260A	803200	756117	906213
806161	752228	906203	756142	750274	804163	756130	906561
806700	752132	906210	756140	750275A	805760	756137	906560
806703	752124	906213	756117	750295	804161	756138	906660
806705	752143A	906300	756139A	750296A	804160	756139A	906300
806707	752144A	906400	756176	750297	805161	756140	906210
806710	752133	906403	756175	750298A	805160	756141	906200
806720	752125	906560	756137	750313	804130	756142	906203
806723	752159	906561	756130	750331	804162	756153	907360
806760	752130	906660	756138	750332	805162	756164A	907561
806761	752140	906661	756214	750333	805163	756165B	907560
806762	752157	906662	756182A	750334	803173	756170	907200
806763	752147	906760	756174	750335	803168	756171	907210
806764	752203	907200	756170	752103A	806160	756174	906760
806765	752204	907210	756171	752123	806766	756175	906403
806766	752123	907300	756207	752124	806703	756176	906400
806767	752231	907360	756153	752125	806720	756179A	907361
807700	752154	907361	756179A	752130	806760	756182A	906662
807703	752185	907560	756165B	752132	806700	756195	908362
807710	752156A	907561	756164A	752133	806710	756199	908361
807760	752169	907600	756217	752140	806761	756200	908560
807761	752170	908200	756204	752143A	806705	756201	908500
807762	752186A	908360	756203	752144A	806707	756203	908360
807763	752171	908361	756199	752147	806763	756204	908200
807764	752160	908362	756195	752154	807700	756207	907300
807765	752161	908500	756201	752156A	807710	756214	906661
807766	752232	910200	756200	752157	806762	756217	907600
808700	752202A	912200	758152	752159	806723	758152	910200
808760	752205	912210	758172	752160	807764	758155A	912210
808761	752206A	912500	758184	752161	807765	758172	912200
808762	752213	916500	758186	752169	807766	758184	912500
						758186	916500



# TECUMSEH SERVICE IS ORGANIZATION

Tecumseh Parts Depot Division employs a staff of over 150 people involved only in Service Support.

Factory Service Representatives located in Field Territories

\*Factory Service Coordinators handle direct telephone communications

Tecumseh Central Warehouse Distributors that are the best in the industry

Parts & Service Distributors located in every Trade Area

Parts & Service Dealers - over 15,000 strong, everywhere in the USA, Canada, plus a world wide Parts & Service Organization. You'll find them fast in the Yellow Pages listed under "Engines, Gasoline".

# TECUMSEH SERVICE IS PERFORMANCE

\*WATS line CWD emergency order system

24 hour shipment of authorized emergency orders

Pre-season computerized parts stocking

\*Distributor stock analysis for continuous parts stock availability

Annual Dealer performance evaluation



# TECUMSEH SERVICE IS SUPPORT

Factory & Field Schools - Intensive Dealer education

\*Territory by territory Dealer parts stocking programs

\*Individual product and customer stocking guidance tailored to need

\*No penalty/No limit Dealer Stock Adjustment Program

\*Finest Warranty Program in the Industry - Full shop labor rate plus parts profit

\*UNIQUE in the Engine and Transmission Industry

