

FIREPOWER

Playfield Lamp Wiring Diagram (System 6)

BOARD CONNECTIONS:	
1	CPU BOARD
2	DRIVER BOARD
3	POWER SUPPLY BOARD
4	MASTER DISPLAY BOARD
5	SLAVE DISPLAY BOARD
6	BACKBOX
7	CABINET
8	PLAYFIELD
9	INSERT BOARD
10	SOUND BOARD
11	NOT ASSIGNED
12	SPEECH MODULE

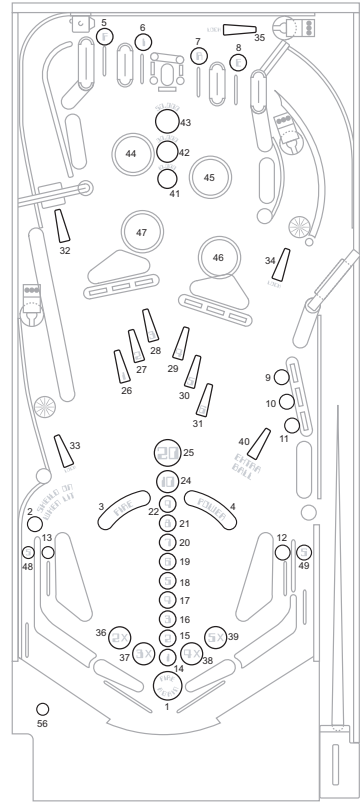

Location of lamps on playfield

DIAGNOSTICS

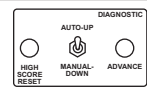

Lamp Test – Test 01
 This test causes all multiplexed lamps to blink on and off. Note that general illumination lamps are not controlled by this test or by any test. Proceed as follows:

- Enter the Lamp Test in one of the following ways:
 - From the Display Digits test, set the AUTO UP/MANUAL-DOWN switch to AUTO-UP and momentarily depress the ADVANCE pushbutton.
 - From the game over mode, (1) Set the AUTO-UP/ MANUAL-DOWN switch to MANUAL-DOWN and momentarily depress the ADVANCE pushbutton.

(2) Set the switch to AUTO-UP and operate the ADVANCE pushbutton until 01 is indicated on the number of credits display.

The multiplexed lights should blink on and off.

2. If no further tests are required, turn the game OFF and back ON to return to the game over mode.

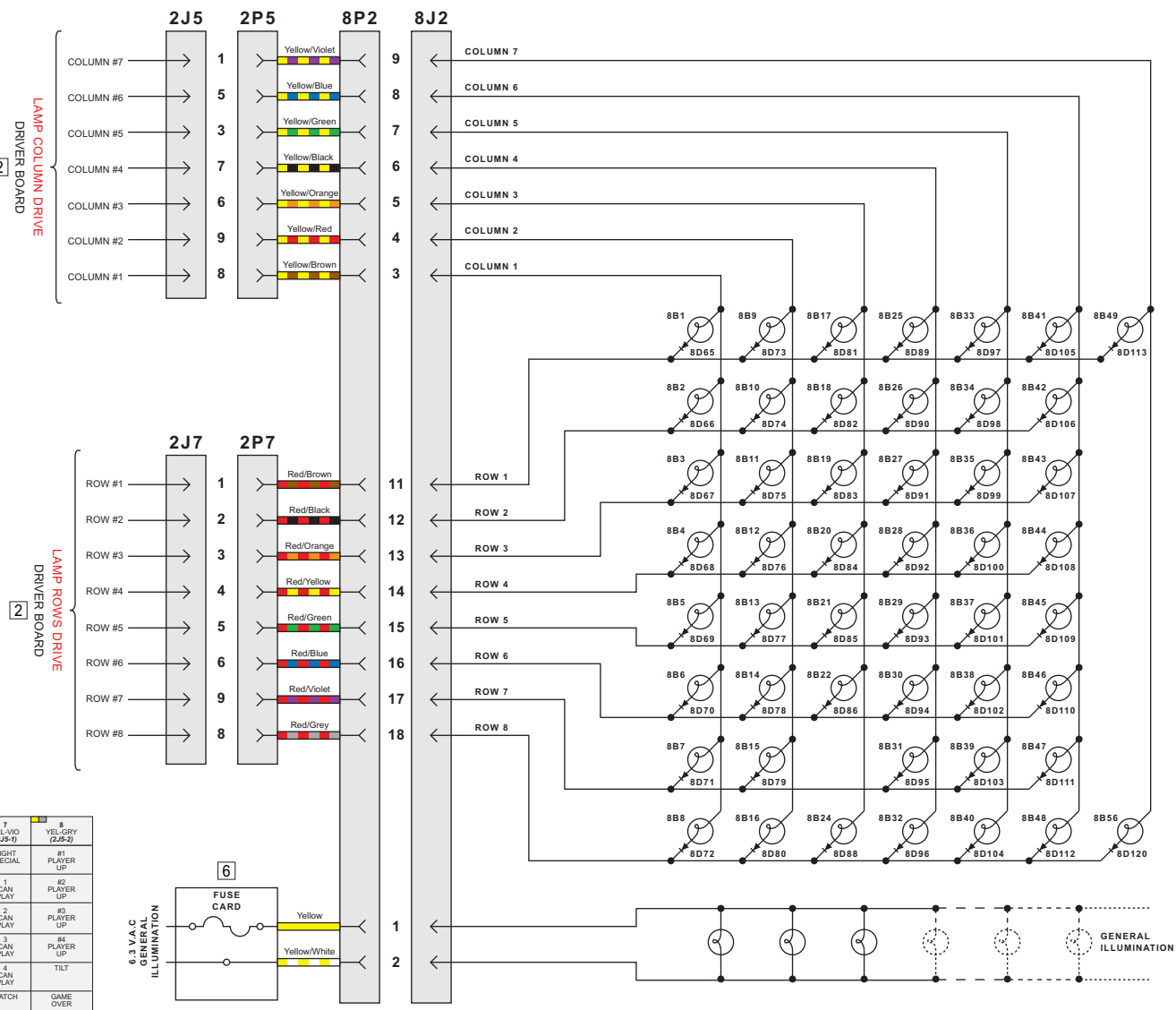

BULB NO.	FUCTION
1	Same Player Shoots Again
2	Ball Saver Kicker On
3	FIRE (x2)
4	POWER (x2)
5	"F"
6	"I"
7	"R"
8	"E"
9	Top POWER Target
10	Center POWER Target
11	Bottom POWER Target
12	Right Inside Rollover
13	Left Inside Rollover
14	1000 Bonus
15	2000 Bonus
16	3000 Bonus
17	4000 Bonus
18	5000 Bonus
19	6000 Bonus
20	7000 Bonus
21	8000 Bonus
22	9000 Bonus
23	Not Used
24	10,000 Bonus
25	20,000 Bonus
26	"1" Drop Target Arrow
27	"2" Drop Target Arrow
28	"3" Drop Target Arrow
29	"4" Drop Target Arrow
30	"5" Drop Target Arrow
31	"6" Drop Target Arrow
32	Spinner 1000 When Lit
33	Left Eject Hole Arrow
34	Right Eject Hole Arrow
35	Upper Right Eject Hole Arrow
36	2X
37	3X
38	4X
39	5X
40	Extra Ball When Lit
41	10,000 FIREPOWER Bonus
42	30,000 FIREPOWER Bonus
43	50,000 FIREPOWER Bonus
44	Top Left Jet Bumper
45	Top Right Jet Bumper
46	Bottom RightJet Bumper
47	Bottom Left Jet Bumper
48	Left Special
49	Right Special
56	Credits (Playfield)

COL	1	2	3	4	5	6	7	8
ROW	1	2	3	4	5	6	7	8
1	RED-BRN (2J5-8)	YEL-RED (2J5-9)	YEL-GRN (2J5-6)	YEL-BLK (2J5-7)	YEL-BLU (2J5-5)	YEL-VIO (2J5-1)	YEL-GRY (2J5-2)	
2	RED-BRN (2J7-1)	BLK (2J7-2)	BLK (2J7-3)	BLK (2J7-4)	BLK (2J7-5)	BLK (2J7-6)	BLK (2J7-7)	BLK (2J7-8)
3	RED-GRN (2J7-3)	GRN (2J7-4)	GRN (2J7-5)	GRN (2J7-6)	GRN (2J7-7)	GRN (2J7-8)	GRN (2J7-9)	GRN (2J7-10)
4	RED-VIO (2J7-4)	VIO (2J7-5)	VIO (2J7-6)	VIO (2J7-7)	VIO (2J7-8)	VIO (2J7-9)	VIO (2J7-10)	VIO (2J7-11)
5	RED-BLU (2J7-5)	BLU (2J7-6)	BLU (2J7-7)	BLU (2J7-8)	BLU (2J7-9)	BLU (2J7-10)	BLU (2J7-11)	BLU (2J7-12)
6	RED-BLK (2J7-6)	BLK (2J7-7)	BLK (2J7-8)	BLK (2J7-9)	BLK (2J7-10)	BLK (2J7-11)	BLK (2J7-12)	BLK (2J7-13)
7	RED-GRY (2J7-7)	GRY (2J7-8)	GRY (2J7-9)	GRY (2J7-10)	GRY (2J7-11)	GRY (2J7-12)	GRY (2J7-13)	GRY (2J7-14)
8	RED-BRN (2J7-8)	BLK (2J7-9)	BLK (2J7-10)	BLK (2J7-11)	BLK (2J7-12)	BLK (2J7-13)	BLK (2J7-14)	BLK (2J7-15)

