

FIREPOWER

Power Wiring Diagram (System 6)

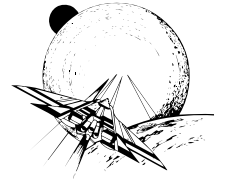

BOARD CONNECTIONS:	
1	CPU BOARD
2	DRIVER BOARD
3	POWER SUPPLY BOARD
4	MASTER DISPLAY BOARD
5	SLAVE DISPLAY BOARD
6	BACKBOX
7	CABINET
8	PLAYFIELD
9	INSERT BOARD
10	SOUND BOARD
11	NOT ASSIGNED
12	SPEECH MODULE

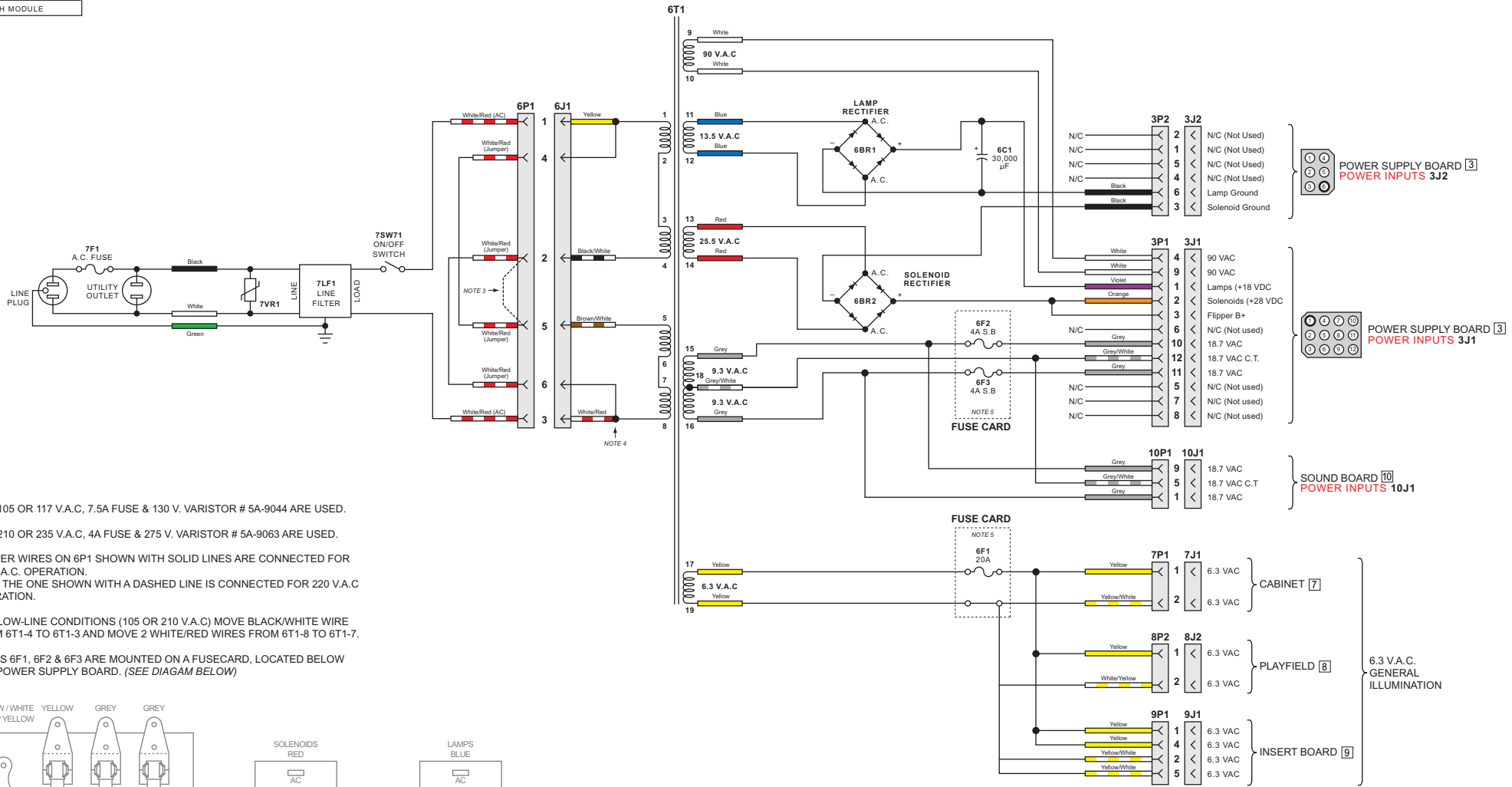

NOTES:

- FOR 105 OR 117 V.A.C, 7.5A FUSE & 130 V. VARISTOR # 5A-9044 ARE USED.
- FOR 210 OR 235 V.A.C, 4A FUSE & 275 V. VARISTOR # 5A-9063 ARE USED.
- JUMPER WIRES ON 6P1 SHOWN WITH SOLID LINES ARE CONNECTED FOR 117 V.A.C. OPERATION. ONLY THE ONE SHOWN WITH A DASHED LINE IS CONNECTED FOR 220 V.A.C OPERATION.
- FOR LOW-LINE CONDITIONS (105 OR 210 V.A.C) MOVE BLACK/WHITE WIRE FROM 6T1-4 TO 6T1-3 AND MOVE 2 WHITE/RED WIRES FROM 6T1-8 TO 6T1-7.
- FUSES 6F1, 6F2 & 6F3 ARE MOUNTED ON A FUSECARD, LOCATED BELOW THE POWER SUPPLY BOARD. (SEE DIAGRAM BELOW)

